

# Sumo Heavy Equipment Trailer

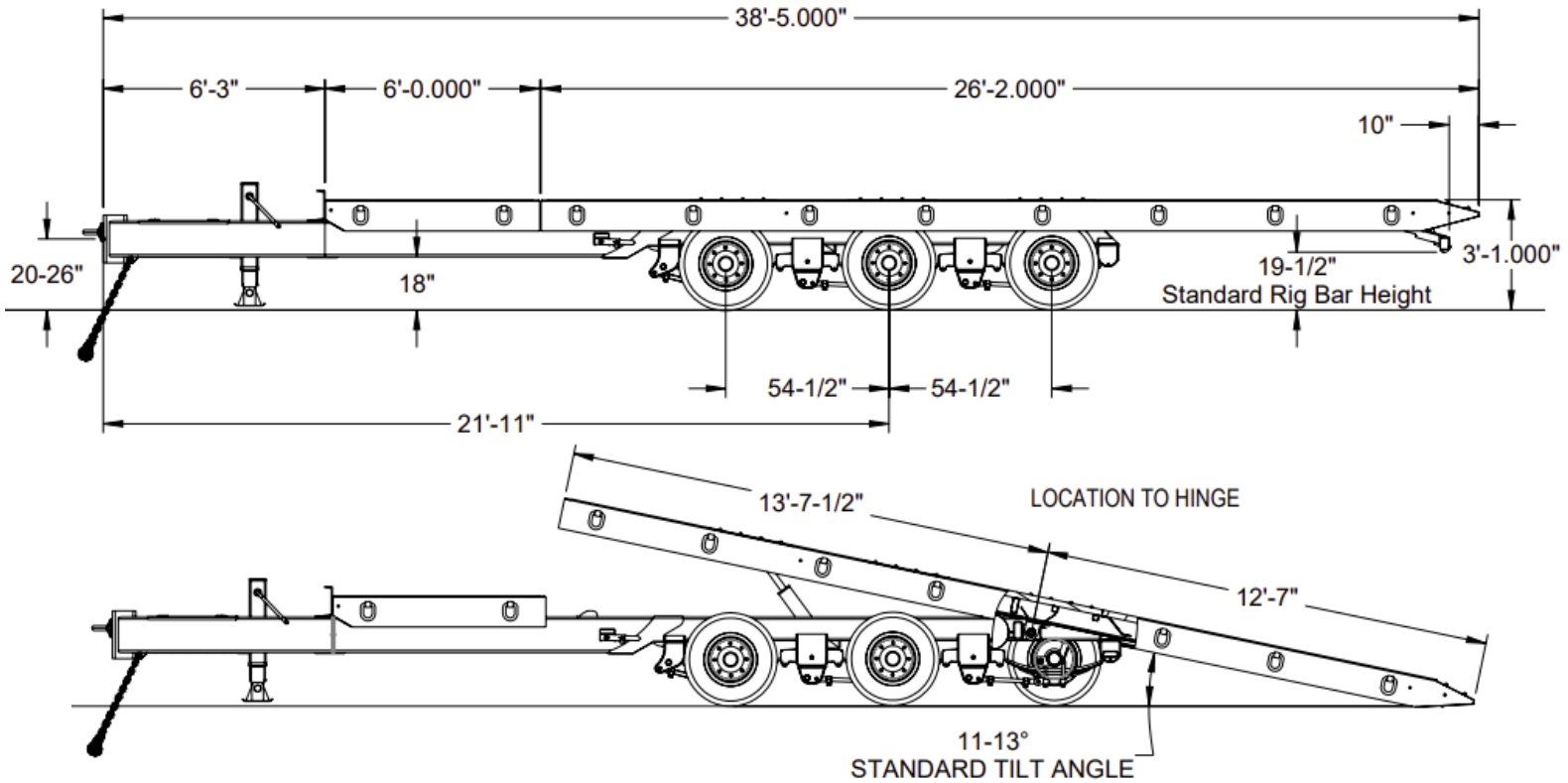

GVWR	73,760 lbs
GAWR	68,100 lbs
Base Trailer Weight	13,760 lbs
Capacity (Distributed)	60,000 lbs
Frame Construction	<ul style="list-style-type: none"> <li>Subframe-Heavy wall tubular beams, with 12x4 &amp; 8x4 Structural Beams, 8x8 Faceplate</li> <li>Deck- Grade 50 I-beam Longitudinal Beams, Grade 50 Channel Perimeter Rails</li> </ul>
Crossmembers	5x2 Tubular Crossmembers
Hitch	90,000 lb Capacity 3" Drawbar
Landing Gear	1- 2-speed Jost Jack, 27,500 lb Lift Capacity, 80,000 Static Load Capacity
Safety Chains	Qty 2- 1/2" Gr. 50 Safety Chain with Hook, 36" Long
Load Securement	Qty 20 - 1" D-Rings, Working Load Limit of 15,586 lbs, Min Break Strength of 46,758 lbs
Tool Compartment	In Tongue Toolbox, with Lockable Lid
Axles	Qty 3 - 25,000 lb Capacity, Center Axle ABS, Front/ Rear Non-ABS
Hubs	Oil Bath Type, 8 on 275mm Bolt Pattern
Brakes	S-Cam Full Air Brakes, Auto Slack Adjusters, Equipped with 2S/2M ABS
Suspension	Heavy Duty Mechanical Spring Suspension, Tri-Axle with Axle Alignment Capabilities
Wheels	6.75 x 17.5 Dual Wheels
Tires	235/75R 17.5 Load Range J, Capacity - 5675 lbs per Tire
Finish Preparation	Sand Blast
Finish Coating	Powder Coat
Electrical Harness	Phillips Sealed Wiring Harness and Lights
Decking	2" True Rough Cut Doug Fir Lumber